

**STRAIGHT JACK SOLDER TYPE**

**R113.223.020**

**CABLE .085**

Series : MCX

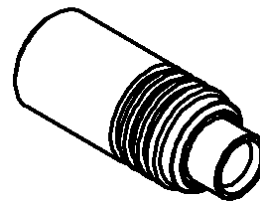
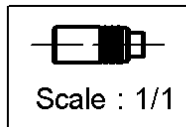
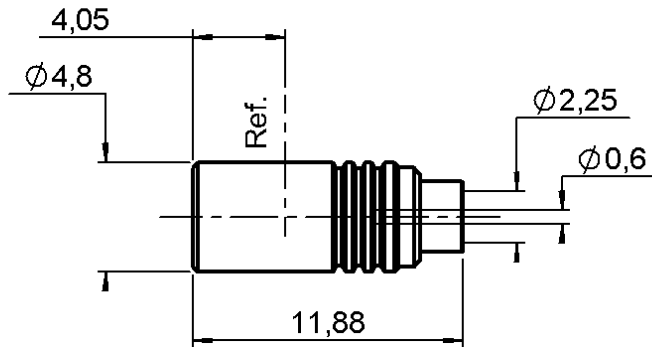

CECC 22221-MCX



All dimensions are in mm.

COMPONENTS	MATERIALS	PLATINGS (µm)
BODY	BRASS	BBR 2
CENTER CONTACT	BERYLLIUM COPPER	.GOLD 1.3 OVER NICKEL 2
OUTER CONTACT	-	-
INSULATOR	PTFE	-
GASKET	-	-
OTHERS PARTS	-	-
-	-	-
-	-	-

Issue : 0108 D

In the effort to improve our products, we reserve the right to make changes judged to be necessary.



**STRAIGHT JACK SOLDER TYPE**

**R113.223.020**

**CABLE .085**

Series : MCX

**PACKAGING**

Standard	Unit	Other
<b>100</b>	-	<b>Contact us</b>

**SPECIFICATION**

**ELECTRICAL CHARACTERISTICS**

Impedance		<b>50</b> Ω
Frequency		<b>0-3</b> GHz
VSWR	<b>1.10 +</b>	<b>0,1000</b> x F(GHz) Maxi
Insertion loss		<b>NA</b> √F(GHz) dB Maxi
RF leakage	- (	<b>NA</b> - F(GHz)) dB Maxi
Voltage rating		<b>250</b> Veff Maxi
Dielectric withstanding voltage		<b>750</b> Veff mini
Insulation resistance		<b>1000</b> MΩ mini

**CABLE ASSEMBLY**

Stripping	a	b	c	d	e	f
mm	2,70	0,00	0,00	0,00	2,10	0,00

Assembly instruction :

Recommended cable(s)  
KS 1  
RG 405

Cable retention

- pull off **155** N mini  
- torque **NA** N.cm

**MECHANICAL CHARACTERISTICS**

Center contact retention		
Axial force – Mating end	<b>NA</b>	N mini
Axial force – Opposite end	<b>NA</b>	N mini
Torque	<b>NA</b>	N.cm mini

**TOOLING**

Part Number	Description	Hexagon
.	.	.
R282.740.020	SOLDERING MOUNTING	

Recommended torque		
Mating	<b>NA</b>	N.cm
Panel nut	<b>NA</b>	N.cm
Clamp nut	<b>NA</b>	N.cm
A/F clamp nut	<b>0,0000</b>	mm

Mating life	<b>0</b>	Cycles mini
Weight	<b>0,9440</b>	g

**OTHERS CHARACTERISTICS**

-

**ENVIRONMENTAL**

Operating temperature	<b>-55/+115</b>	° C
Hermetic seal	<b>NA</b>	Atm.cm3/s
Panel leakage	<b>NA</b>	

Issue : 0108 D

In the effort to improve our products, we reserve the right to make changes judged to be necessary.



**STRAIGHT JACK SOLDER TYPE**

**R113.223.020**

**CABLE .085**

Series : MCX

**COMPONENT**

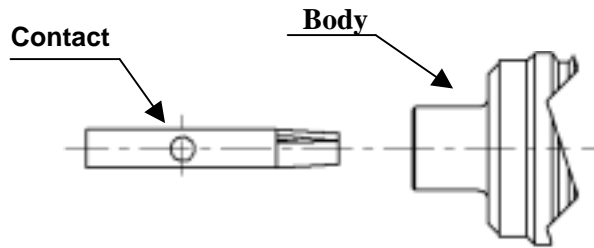

**STRIPPING DIMENSIONS**

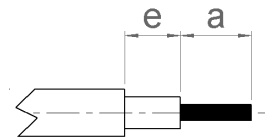

We recommend a thermal preconditioning cable.

**1**

Cable stripping.

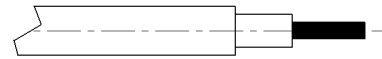

**2**

Tin centre contact solder pot.  
Solder centre contact on cable inner conductor.  
Clean solder.



**3**

Introduce cable into the connector body until contact with the body shoulder.  
Place the sub assembly into the assembly jig R282 740 020 (or equivalent).  
We advise to connect a female receptable to the connector prior to solder the body in order to respect right centre contact position.  
Tighten the sub assembly.  
Solder body on the cable.  
Let the assembly cool down before removing it from the jig.  
Clean solder.

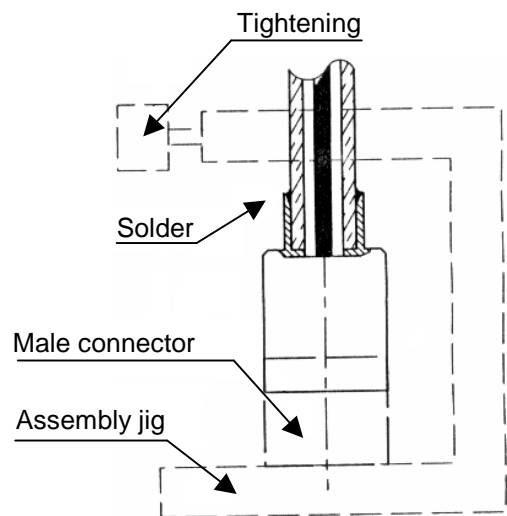

**Issue : 0108 D**

In the effort to improve our products, we reserve the right to make changes judged to be necessary.

